

# EW50 Series

## Industrial LTE Cellular Gateway

Stay Connected 24-7, Reliable High-Speed Communications



## Overview

The EW50 is an intelligent industrial grade gateway designed for critical infrastructure and industrial applications. It provides reliable and secure connectivity designed for harsh environments, giving operations and IT real-time awareness with remote monitoring. Moreover, it delivers best-in-class multi-path connectivity with Wireless, Ethernet, serial, and digital I/O to satisfy most applications. Global LTE options make it easy to get connected.

EtherWAN — "When Connectivity is Crucial."

## Spotlight

### • Flexible Configurations with Reliable Connectivity

- Ethernet, serial, DI/DO and Modbus bridging for connecting diverse field assets
- Ideal for M2M and industrial IoT applications

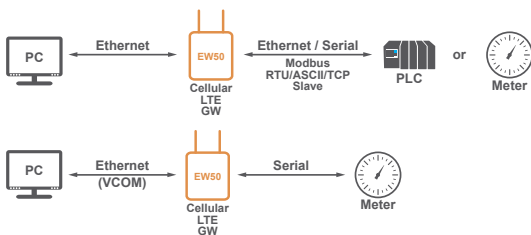

### • Reliable and Uninterrupted Connection

- Equipped with dual SIM cards for failover
- Failover management for network reliability and uninterrupted uptime
- Always online 4G LTE internet connection/IP Passthrough Mode

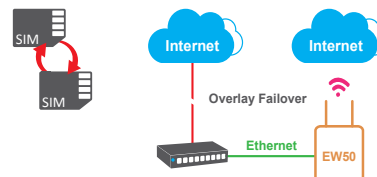
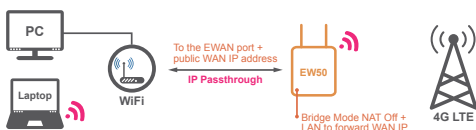

## • Comprehensive Data Security

- IPSec, OpenVPN, PPTP, and L2TP VPN support up to 16 concurrent tunnels with max 70Mbps throughput (IPSec)

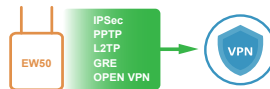

## • Rugged Industrial Design

- Features metal housing with fan-less cooling, IP30
- Supports operating temperature from -30 to 70°C (-22 to 158°F)

## Features

- Global HSPA+ and 4G LTE support, and certified for the world's major carrier networks
- Ethernet, serial, DI/DO and Modbus bridging for connection of diverse field assets
- Equipped with a dual Micro-SIM LTE module with failover function
- 10/100/1000BASE-TX Ethernet port with tag based and port based VLANs for easy control of groups and traffic
- IPSec, OpenVPN, PPTP, and L2TP VPN support for up to 16 concurrent tunnels with max 70Mbps throughput (IPSec)
- Firewall with SPI and IPS to prevent intrusion
- SNMP and Telnet CLI for system management

## Frequency Bands Region Code

SKU Code	4G LTE		3G	2G	Region
	FDD LTE	TDD LTE	WCDMA	GSM/EDGE	
<b>TA</b>	B1(2100)/3(1800)/ 4(AWS)/5(850)/ 7(2600)/8(900)/ 28(700 APT)	B40(2300)	B1(2100)/2(1900)/5(850)/ 8(900)	B2(1900)/3(1800)/ 5(850)/8(900)	<b>Taiwan, Australia</b>
<b>EUS</b>	B1(2100) / 3(1800) / 5(850)/ 7(2600) / 8(900) / 20(800)	B38(TD 2600)/ 40(TDV 2300)/ 41(TD 2500)	B1/B5/B8	B3(1800)/8(900)	<b>EU, Singapore, Malaysia, Vietnam, Thailand, Turkey, Philippines, India, Indonesia, South Korea</b>
<b>JP</b>	B1(2100)/B3(1800)/ B8(900)/B18(800 Lower)/ B19(800 Upper)/B26	B41(TD 2500)	B1(2100)/6(UMTS only)/ 8(900)/19(800 Upper)	–	<b>Japan</b>

# Hardware Specifications

## Cellular Interface

---

### Standards

- Cellular Frequency Bands: (Please check Frequency Band Regional Codes)
- LTE Cat. 4: FDD-LTE, TDD-LTE, Transfer rate (max):  
LTE FDD: 150Mbps down; 50Mbps up  
LTE TDD: 130Mbps down; 35Mbps up
- 3G: WCDMA, Transfer rate (max): 42Mbps down; 5.76Mbps up
- 2G: GSM/EDGE, Edge Transfer rate (max): 236.8Kbps down & up

### Antenna connector

- 2 x SMA Female

### SIM Slot

- 2

## Ethernet

---

### Standards

- IEEE 802.3 10BASE-T
- IEEE 802.3u 100BASE-TX/100BASE-FX
- IEEE 802.3ab 1000BASE-T

### Ports

- 2 x RJ45 GE

### Physical Layer

- 10/100/1000BASE-T

## Serial

---

### Ports

- 2 x RS-232/RS-485

## I/O

---

### DI/DO

- 1 x Digital In ("Logic 0": 0-2V, "Logic 1": 5-30V)
- 1 x Digital Out (Relay Mode, up to 30V/1A)

## USB

---

### Standards

- USB 2.0

### Ports

- 1 x USB Type A

## Micro SD

---

### Capacity

- Max. Storage of 64GB

## Functions

---

### VLAN

- Port-based, Tag-based VLAN

### Port Forwarding

- Virtual Server/Computer (1-1), DMZ Host, PPTP/L2TP/IPSec Pass-through

### Routing

- Static, Dynamic: RIP1/RIP2, OSPF, BGP

### VPN

- IPSec, OpenVPN, PPTP, L2TP, GRE

### Firewall

- SPI Firewall with Stealth Mode, IPS

### Event Engine/Event Handling

- Managing/Notifying Events: DI, DO, Modbus, SMS, Syslog, SNMP Trap, Email Alert, Reboot

## Cloud Development Platform

---

- Support Microsoft Azure

## Field Communication

---

### Virtual COM

- RFC2217, TCP Client, TCP Server, UDP

### Modbus

- Gateway for Modbus TCP, Modbus RTU/ASCII Master/Slave Access
- Slave for Device Status/Information Access

### Data Logging

- Sniffer, Off-line/Full-time Proxy, Mixed modes

### Data Interchange

- MQTT Broker, MQTT Client

## Power

---

### Input

- DC 9-36V

### Power consumption

- 7.0W Max.

## Mechanical

---

### Dimension

- 31 x 99 x 130.6mm (w/o mounting brackets)

### Weight

- 0.9Kg (1.98lb)

### Installation

- DIN-Rail

## Environment

---

### Operating Temperature

- -30 to 70°C (-22 to 158°F)

### Storage Temperature

- -40 to 85°C (-40 to 185°F)

### Ambient Relative Humidity

- 5% to 95% (non-condensing)

## Regulatory Approvals

---

### Safety

---

EN 60950-1

EN 62368-1: 2014

### Emissions/Immunity

---

EW50-TA FCC/NCC/RCM

EW50-EUS FCC/CE/NBTC/NTC/KC\*/SDPPI\*\*

EW50-JP VCCI/JATE

### Note:

**KC\***: EW50-EUS for south Korea only supports Roaming and MVNO SIM

**SDPPI\*\***: Indonesia Radio Type Approval 78410/SDPPI/2021

13696

# Application Diagram

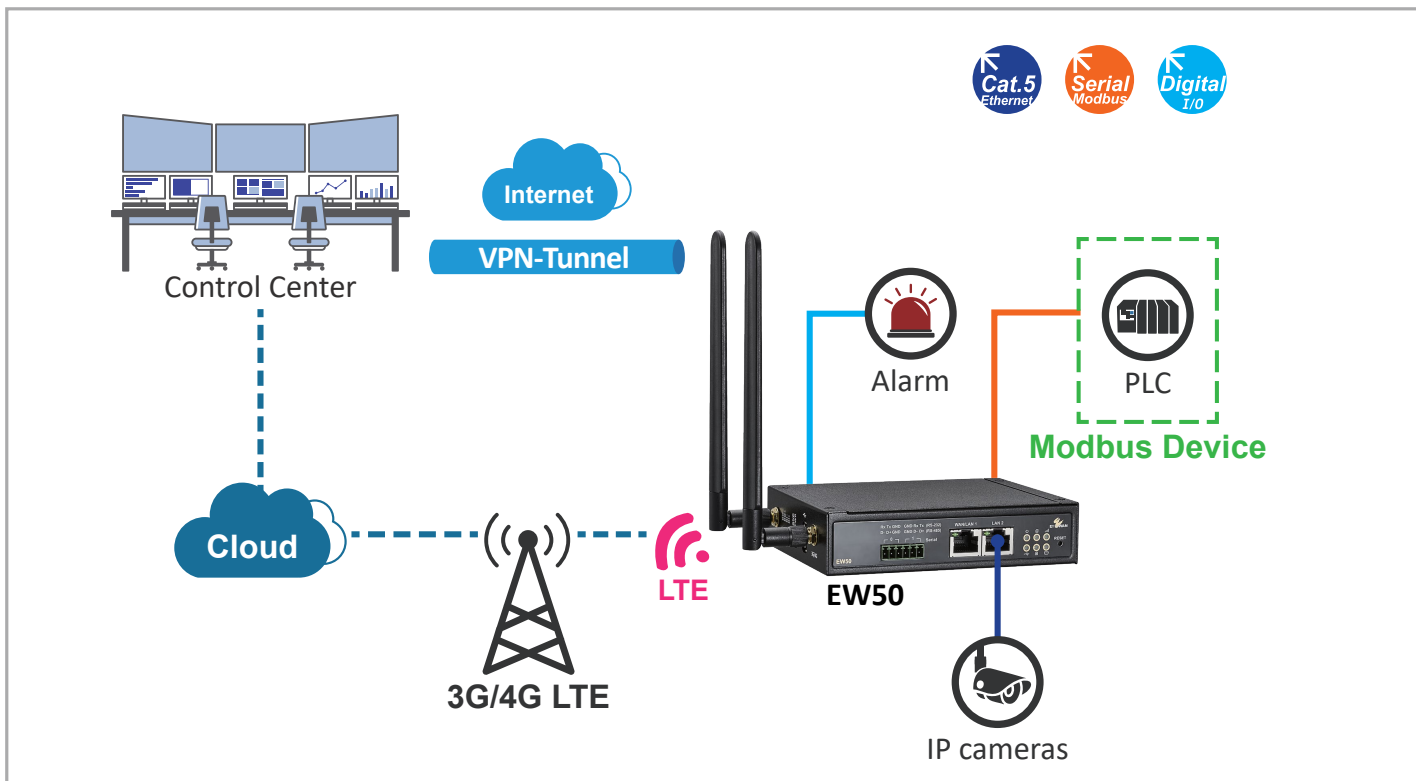

# Dimensions

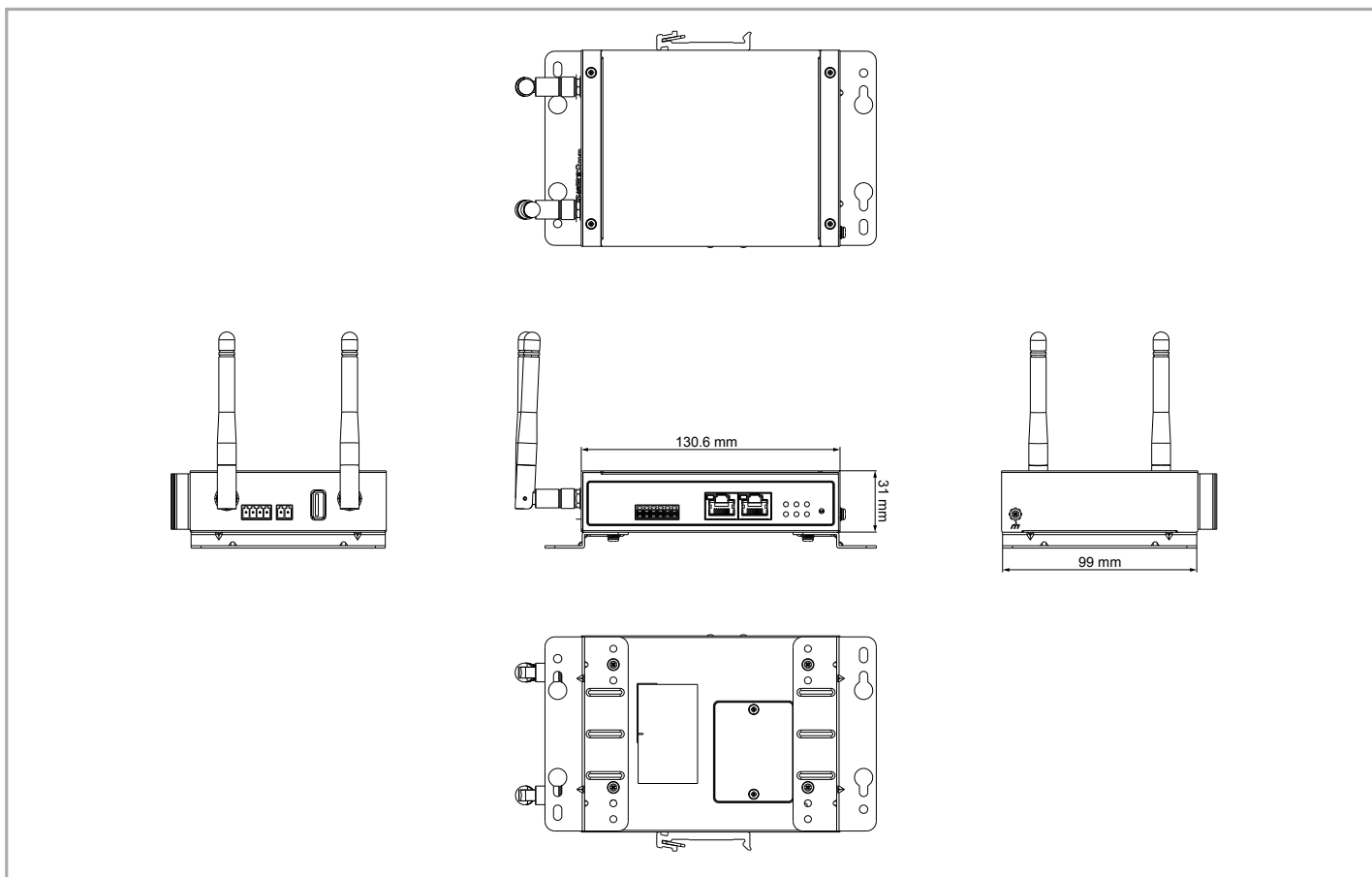



## Ordering Information

### Model

<b>EW50-EUS</b>	Industrial LTE Cellular Gateway-EUROPE & SOUTH ASIA
<b>EW50-TA</b>	Industrial LTE Cellular Gateway-TAIWAN & AUSTRALIA
<b>EW50-JP</b>	Industrial LTE Cellular Gateway-JAPAN

### Optional Accessories

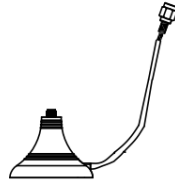
<b>GWAP-1</b>	<b>Item</b>	<b>Amount</b>	<b>Frequency</b>	<b>Description</b>	<b>Note</b>
	LTE	2	698-960/ 1710-2170/ 2300-2690MHz	Cellular Omni Antenna, N/female Jack Bulkhead	IP67
	Surge Protector	2	—	0-6GHz Surge Lightning Protector, N/female Jack Bulkhead To N/male Plug	IP67
	Bracket	2	—	—	—
	LTE Cable	2	—	SMA/male Plug To N/male Plug with NFC200 Cable	—

<b>P/N.</b>	<b>Image</b>	<b>Item</b>	<b>Amount</b>	<b>Frequency</b>	<b>Description</b>	<b>Note</b>
<b>W96G-GY113HT46*</b>		Cellular Antenna Base	1	—	This antenna base can be used on EW50 / EW200 / AiR PACE LTE antenna to extend 1.5M. Each model needs 2 antenna bases. This antenna base is not IP67.	—
<b>W96G-11361Y50S</b>		Wall Mount Kit	1 set	—	1 set package includes 2 wall mount (Right side & Left side) & 4 pcs screws	—

\* Please be noted that these accessories are not for JP market.